

STUDIA IN HONOREM ILIAE ILIEV

Регионален исторически музей - Ямбол
Вести на Ямболския музей, година VI, брой 9

Регионален исторически музей - Ямбол



STUDIA IN HONOREM ILIAE ILIEV

Ямбол 2019 Yambol

Вести на Ямболския музей /година VI, бр. 9

YAMNAYA – CORDED WARES – BELL BEAKERS, OR HOW TO CONCEPTUALIZE EVENTS OF 5000 YEARS AGO THAT SHAPED MODERN EUROPE

Volker Heyd

The third millennium BC has been considered for decades as one of the most interesting epochs in European prehistory. With Yamnaya, Globular Amphorae, Corded Wares, Bell Beakers and then the Early Bronze Age we have something extraordinary in store; no cultures in the actual archaeological sense. Keywords such as *super-regional distributions*, *ideologies*, *burial cultures*, *emblematic ceramics*, and *East and West* may best describe the situation in a given briefness.

Of course, archaeological research had already noticed this particular finding situation a long time ago, describing the third millennium as the age of a great shake-up, of potential migrations and of immense cultural change. One only needs to be reminded of Marija Gimbutas' *Kurgan theory* (Gimbutas 1981), Andrew Sherratt's *Secondary Products Revolution* (Sherratt 1981), Kurt Gerhardt's ominous *planoccipitaler Steilkopf* of the Bell Beakers (Gerhardt 1953), or Edward Sangmeister's *Reflux Theory* (Sangmeister 1966), all born out from the 1960s to the 1980s.

Nevertheless, no one would have thought it possible that the changes would be as revolutionary as now recognized -- a true turning point on the way to modern Europe, as we otherwise only know it in connection with the first farmers of the Continent, the Roman Empire, the Migration Period, the 30-Years-War, or WW1.

THE THIRD SCIENTIFIC REVOLUTION IN ARCHAEOLOGY

Interwoven is this new understanding of the third millennium with a revolution that is currently taking place within archaeology itself and of which we do not yet know where it is going to lead us. Genetics, isotopes, proteins and lipids, a significantly improved physical anthropology, and other scientific applications in physics and geophysics make us aware of it. Computer Science, Big Data Mining, Virtual Reality and Artificial Intelligence are just waiting to be included too.

The Danish archaeologist Kristian Kristiansen rightly described this as the Third Scientific Revolution in Archaeology -- after the impact of Darwin's Evolutionary Theory and then Radiocarbon Dating (Kristiansen 2014). As a result, we are also in the midst of a methodological debate in prehistoric archaeology, which should allow us the theoretical-methodological framework for the embedding of the natural sciences. As a consequence, archaeology, and especially prehistoric archaeology, is becoming closer to the natural sciences. One works inter-disciplinarily and in teams, one publishes in English in global scientific journals, one is increasingly in the press, and benefits from more and higher research funds.

Particularly the cooperation with genetics will seriously challenge our view on the past. Not every archaeologist will like the fact that ethnic dimensions are back on the dinner table since the first publication of third millennium whole-genome evidence in 2015 (Heyd 2017). As for now and probably for another couple of years, it is

mainly the population genetics with all their findings, *re-discoveries* and surprises that is en vogue and stirs up a lot of dust, not only in archaeological circles but also via the press towards a much wider audience (eg. Callaway 2018, Barras 2019).

But much more important will be kinship analysis for our understanding of the past. It is only a matter of time before such ancient DNA (aDNA) tests in archaeology become so affordable that they will stand by default in the grave(yard) analysis alongside radiocarbon dating and an isotopic package. The connection to contemporary, personal DNA data will also become revolutionary. Millions of such records are already available in the US, for example. Whether you think it's good or bad, the time will come when aDNA is compared to personal DNA profiles, and one goes to the museum to visit one's direct ancestor ...

However, before we return to the third millennium BC, another question should be touched briefly:

WHO ARE WE EUROPEANS?

Much has already been written about the *Europeans* and one has often tried to define us. Without a doubt, we are a mixture of different peoples, nations and networking regions, historically grown, and repeatedly interacting with our neighbours. But let's face it: Is there more than Europeans being only a social construct? And what distinguishes us Europeans from the rest of the world, if we go back in time and beyond the beginnings of what is called the 'Christian-Occidental' spiritual and cultural heritage? As a Prehistorian, and with regard to anthropology and genetics, I would first add our language, mostly belonging to the Indo-European language family. Next is it our physiognomy and appearance: distinct faces, eye forms and noses, altogether relatively light-skinned and variable in our hair and eye colours, clearly with a south-north gradient within the continent. Furthermore, we can usually metabolize carbohydrates and alcohol well and are able to digest milk without any problem. Then take into account our body size: on average, we are the tallest people on the planet. Historically, a special social organization predominates: hierarchical and patriarchal; monogamous, exogamous and patrilocal; nuclear and extended families; primogeniture and patrilinear inheritance, etc., and mostly combined in such a way. Finally, we are quite warlike: not only have we decimated ourselves neatly over the last millennia, the rest of the world can also sing a Swan's Song of it; considering, for example, when European nations at the height of Colonialism at the end of the 19th century were controlling more than three quarters of the world, with Britain alone a quarter of the earth's population...

But it does not always seem like that. Examinations of stature of prehistoric peoples see a constant reduction beginning with the first farmers; Europeans of the 4th millennium BC were the shortest of all, shorter than contemporary people in the Middle East, before the trend went *upwards* again (Rosenstock et al. 2016). Also, one may ask how the social organization may have looked in the Linearbandkeramik longhouses, sometimes more than 40 m long (Amkreutz et al. 2016); or on the densely built-up Tell settlements of southeastern Europe; or in the so-called Tripolye *Mega Settlements*? These don't look like nuclear families... Likewise, there are recent research approaches that other Neolithic languages were spoken before the appearance of the Indo-European in Europe (Iversen, Kroonen 2017). These, and some of the aspects mentioned above, are currently hotly debated in prehistoric and prehistory-related interdisciplinary research.

However, what is certain and this is also a continuous trait of the Europeans: We are the product of many migrations. Beginning with the immigration of Homo sapiens; the migration of hunters and gatherers at the start of the Holocene; then the first farmers of Europe; as described above in the third millennium BC; to the historically documented migrations of the Late Bronze Age Sea Peoples; the Greek-Phoenician colonization of the Mediterranean; the Celtic migration; the expansion of the Roman Empire; the Migration Period; the nomadic people of Eurasia; and many more. You could actually continue the list until yesterday and easily add the current migration crisis in Europe. Migrations have shaped us and will continue to alter us. They bring innovation, change and stimulation. But, and that too is part of migration, it is not always a positive experience for the host populace: in retrospect, the administration of the Roman Empire of the Late Antiquity would have wished that the Goths begging to be admitted would never have been received; and likewise the European expansion to central and south America in AD 16th century was not really beneficial for the native populations there, just to mention two serious examples.

Obviously, there are significant physical and structural differences between the Europe of the First Farmers and their immediate descendants, and the Europe and its populations as we know it with the first historical records and on the way to the modern Europe of today. Either a gradual but significant process of tremendous transformation, or a special event, must have occurred in-between. And here comes the third millennium, or more precisely the time around 3000 BC, back into play, because events overlap with an extraordinary formation and migration horizon on the eastern edge of Europe.

ALL BEGINNING WAS YAMNAYA

Already in the last quarter of the 4th millennium, in the steppes between the Caspian Sea and the Black Sea, a process of unification of various groups of Late Copper Age people and populations took place. Fundamental here is the innovation of wheel and wagon (Anthony 2007). Only it allows the waterless steppe away from the rivers to be widely exploited over many months of the year, thus creating the foundation for building up and keeping much larger herds, mainly cattle (Friculeasa et al. 2015). This is accompanied by a fundamentally different way of life in which more and more groups now live a highly mobile life with much wider communication networks and exchange systems. As a result, we see changing material cultures, new forms of settlement, and a wider land use. Groups of people who used to be largely hunters, fishermen and collectors with a few domesticates are now becoming specialized cattle herders (Kaiser 2011). Thus the pastoralism of the steppes is formed. At the same time we recognize a homogenization in the death ritual: The typical Yamnaya burial way is established, consisting of: 1) Burial mounds called Kurgan -- as a landmark in the otherwise flat steppe; 2) burials in supine position with flexed upward standing legs; 3) ochre powder scattering and/or the deposition of ochre lumps; 4) elaborated and decorated grave chambers, of laid out and draped with mats, furs, pillows, etc.; and 5) only few offerings, if any then prestige goods. Along with the herds and the concept of the mound as a landmark goes a novel understanding of ownership, grazing rights and territory. Similarly, the burial mound is considered a monument to the ancestors, someone's own descent and lineage, and thus family and clan. Here, too, a homogenization

seems to have taken place, but one that affects the social organisation, structures and norms, and that forms like-minded pastoralists to equals and culturally common while developing a sense of superiority over neighbours. Thus, an ideology, a 'cultural-economic-social world-view' emerges which, as Social and Evolutionary Anthropology teaches us, is also usually founded cosmologically and religiously.

Although this new way of life and economy had many positive aspects for the groups of people involved, it did bring with it a great disadvantage: the cattle are the wealth of the group and the welfare of the animals is above all else; not only did one have to defend his herd against hostile takeover, but one was now also more susceptible to the rigors of nature, and this in an epoch of progressive precipitation decline in the steppes of eastern Europe. It was probably this permanent search for green pastures that pushed our Yamnaya people and their animals westward. West here means the plains of southeastern and eastern central Europe, which are also covered by steppe vegetation, in today's Moldova, Romania, Bulgaria, Serbia and Hungary (**Fig. 1**). However, this westernmost part of the Eurasian steppe belt was already inhabited by a mosaic of other Late Copper Age/Early Bronze Age populations, cultures and societies (Heyd 2011). What we see subsequently in our archaeological record is what one may confidently coin with the neutral word of *Interaction*, that is the mutual transmission of ideas, innovations and also --as the aDNA results teach us-- genes; in their terminology: 'Admixture'.

One could now list more points related to the Yamnaya westward movement that we know of, or at least partially understand. More interesting, however, are the many unanswered questions without wanting to go into detail here: This includes the role of the domesticated horse in this expansion? Or the responsibility of the plague (*Yersinia pestis*), of which we are also informed by aDNA? Another keyword is demography – Is it really a mass migration we are dealing with? Then the gender ratio within the migrants – is it balanced or rather only young men, as also aDNA and anthropology want to teach us? Or the whole complex of Yamnaya ethnicity versus Yamnaya identity – how is this to be seen? Not to forget is the relationship of Yamnaya and Globular Amphora Culture, especially along the rivers of Prut and Dneestr – What does this tell us about the local element when it comes to the transmission? And finally: Our Yamnaya populations are well adapted to the environment of the steppes with their way of life and economy. But how then are graves to be judged, which were discovered in the last decade in southeastern and eastern central Europe outside these special landscapes? Are these really Yamnaya or are they culturally something else?

These last two questions are important in understanding the mechanisms of propagation of the genetically defined *Yamnaya or Steppe Ancestry* and the origins of Corded Wares and Bell Beakers.

CORDED WARES, BELL BEAKERS AND THE TRANSFORMATION OF EUROPE

If the Yamnaya migration was more of a triggering event, then Europe's great transformations take place only in the wake of the pan-European phenomena of Corded Wares and Bell Beakers. This is undoubtedly the essence of the recent aDNA studies that dramatically show how populations differ before and after (Allentoft et al. 2015; Haak et al. 2015; Olalde et al. 2018; 2019). For example, in the UK, 90% of the Neolithic farmers gene pool, including the builders of Stonehenge,

seems to have been extinguished after the appearance of the first Bell Beaker vessels around 2450 BC (**Fig. 2**). Although one has to take this percentage with a pinch of salt due to sampling bias, these are nevertheless values that come close to a complete population replacement, as we know them in historical time only for some areas devastated by the Thirty Years War in central Europe. Even on the Iberian Peninsula, deep in Western Europe, geneticists find the Yamnaya/steppe ancestry of the newcomers from around 2500 BC in a 40% replacement scenario, however with the fascinating side-kick information that 100% of previous Y-chromosome male lines got extinct in the course of events. Obviously two things comes to one's mind: It was certainly not an advantage to be a man of local origins at that time; and Edward Sangmeister's Bell Beaker *Reflux Theory* certainly had its place.

Both Corded Ware and central/north European Bell Beaker users are genetically direct descendants of Yamnaya populations. Following the latest aDNA revelations there cannot be any doubt in this statement. However there are significant differences: Corded Ware (**Fig. 3**) generally possess more of these Yamnaya ancestry than Bell Beaker people, or in other words, the *local Neolithic element*, established since thousands of years has become more and more noticeable over the centuries between 2900 and 2150 BC. In the case of Corded Ware this *local element* could well be represented by Globular Amphora people but, as it seems, only their women, since the typical Y chromosome lineage of their men (haplotype I2a) seems barely detectable thereafter. Overall, the distribution of Y chromosomes is very interesting. According to current knowledge, almost all Corded Ware males have the haplotype R1a (M417; still the most widespread in Eastern Europe today), while almost all Bell Beaker males belong to the group R1b (M269; the prevalent one in Western Europe). Surprisingly, the latter is also the dominant of the Yamnaya men, albeit in a different sub-type. Figuratively speaking, according to these aDNA results, Corded Wares and Bell Beakers are more older and younger siblings --or perhaps only step-siblings-- of the same Yamnaya (and perhaps Globular Amphorae) parents, than that central European Bell Beaker people themselves descended from Corded Ware. In contrast, western European Bell Beaker people are genetically more likely to be the descendants of local Neolithic populations, partly superimposed by migrants from central Europe (**Fig. 4**). This also reflects the emergence of the Bell Beaker phenomenon between west and east, probably with two interacting centres, as recently shown by Olivier Lemerrier (2018): 1) the west of the Iberian Peninsula and 2) the course of the river Rhine, also as the western border of Corded Wares. The expansion of Corded Wares probably begins more in the east of Europe. A good candidate would be the infiltration of Yamnaya people along the river Dniester, where they subsequently encounter Globular Amphora people. But this is still quite speculative at the moment, as our dataset is weak.

However, the demographics of this transformation still remain a huge mystery, as we only vaguely overlook the mechanics of transmission from Yamnaya, via Corded Ware, to Bell Beakers (**Fig. 5**): Mass immigrations or only regional infiltration; more assimilation of local populations by strangers; or even a genocide of a Continental extent in the third millennium BC; or perhaps diseases like the plague, which weakened previous populations for 500 years and then ravaged through the entire third millennium; or everything together?

No matter, there are undoubtedly huge changes on the way to the populations and the culture of Europe as we know it today. To top it up, there are topics

when dealing with the third millennium BC that were as relevant then as they are today: migration; foreigners' interaction with the locals; reaction of the natives and population replacing; and --also posed by genetics-- the question of ethnicity versus identity, and what shapes us more, our biological part or our culture and society. Archaeology has never been so valuable as it is today! Welcome to an international and interdisciplinary prehistoric archaeology of the AD 21st century...

BIBLIOGRAPHY/БИБЛИОГРАФИЯ:

Allentoft et al. 2015: M. E. Allentoft et al. Bronze Age population dynamics and its impact on modern Eurasian genetic structure. – *Nature*, 522, 2015, 167 - 172.

Amkreutz et al. 2016: L. Amkreutz, F. Haack, D. Hofmann, I. van Wijk (eds.). *Something Out of the Ordinary? Interpreting diversity in the Early Neolithic Linearbandkeramik and beyond*. Cambridge, 2016.

Anthony 2007: D.W. Anthony. *The Horse, the Wheel and Language. How Bronze-Age riders from the Eurasian steppes shaped the Modern World*. Princeton/Oxford, 2007.

Barras 2019: C. Barras. The tribe that rewrote history. DNA reveals the untold story of the ultimate Stone Age conquerors. – *New Scientist*, 3223, 2019, 29 - 33.

Callaway 2018: E. Callaway. The battle for common ground. Ancient genomes are revolutionizing the study of human prehistory but sometimes straining the relationships between archaeologists and geneticists. – *Nature*, 555, 2018, 573 - 576.

Frînculeasa, Preda, Heyd 2015: A. Frînculeasa, B. Preda, V. Heyd. Pit-Graves, Yamnaya and Kurgans along the Lower Danube. – *Praehistorische Zeitschrift* 90, no.1/2, 2015, 45 - 113.

Gerhardt 1953: K. Gerhardt. *Die Glockenbecherleute in Mittel- und Westdeutschland*. Stuttgart, 1953.

Gimbutas 1981: M. Gimbutas. The three waves of the Kurgan people into Old Europe, 4500 - 2500 BC. – *Archives suisses d'anthropologie générale* 43/2 (1979), 1981, 113 - 137.

Goslar, Koško 2011: T. Goslar, A. Koško. Z badań nad chronologią i topogenezą kujawskich kurhanów staroszurowych. Krusza Zamkowa, powiat Inowrocław, stanowisko 3. – In: H. Kowalewska-Marszałek, P. Włodarczak (eds), *Kurhany i obrządek pogrzebowy w IV - II tysiącleciu p. n. e.* Kraków & Warszawa, 2011, 407 - 415.

Haak et al. 2015: W. Haak et al. Massive migration from the steppe was a source for Indo-European languages in Europe. – *Nature*, 522, 2015, 207 - 211.

Heyd 2011: V. Heyd. Yamnaya groups and tumuli West of the Black Sea. – In: E. Borgna, S. Müller-Celka (eds.), *Ancestral Landscapes: Burial mounds in the Copper and Bronze Ages*. Lyon, 2011, 535 - 555.

Heyd 2017: V. Heyd. Kossinna's Smile. – *Antiquity*, 91 (356), 2017, 348 - 359.

Iversen, Kroonen 2017: R. Iversen, G. Kroonen. Talking Neolithic: Linguistic and Archaeological Perspectives on How Indo-European Was Implemented in Southern Scandinavia. – *American Journal of Archaeology*, 121, 4, 2017, 511 - 525.

Kaiser 2011: E. Kaiser, 2011. Der Übergang zur Rinderzucht im nördlichen Schwarzmeerraum. – *Godisnjak (Sarajevo)*, 39, 2011, 23 - 34.

Kristiansen 2014: K. Kristiansen. Towards a new paradigm? The Third Science Revolution and its Possible Consequences in Archaeology. – *Current Swedish Archaeology*, 22, 2014, 11 - 34.

Lemercier 2018: O. Lemercier. Think and Act. Local Data and Global Perspectives in Bell Beaker Archaeology. – *Journal of Neolithic Archaeology*, 20, 2018, 77 – 96.

Olalde et al. 2018: I. Olalde et al. The Beaker phenomenon and the genomic transformation of northwest Europe. – *Nature*, 555, 2018, 190 - 196.

Olalde et al. 2019: I. Olalde et al. The genomic history of the Iberian Peninsula over the past 8000 years. – *Science*, 363 (6432), 2019, 1230 - 1234.

Rosenstock et al. 2016: E. Rosenstock, M. Groß, A. Hujčić, A. Scheibner. Back to good shape: biological standard of living in the Copper and Bronze Ages and the possible role of food. – In: J. Kneisel, M. Dal Corso, W. Kirleis, H. Scholz, N. Taylor, V. Tiedtke (eds.), *The Third Food Revolution?: Setting the Bronze Age Table*. Bonn, 2016, 121 - 151.

Sangmeister 1966: E. Sangmeister. Die Datierung des Rückstroms der Glockenbecher und ihre Auswirkungen auf die Chronologie der Kupferzeit in Portugal. – *Palaeohistoria*, 12, 1966, 395 - 407.

Sherratt 1981: A. Sherratt. Plough and pastoralism: aspects of the secondary products revolution. – In: I. Hodder, G. Isaac, N. Hammond (eds.), *Pattern of the Past. Studies in honour of David Clarke*. Cambridge, 1981, 261 - 305.

Vergnaud 2014: L. Vergnaud. Les sépultures campaniforme de Sierentz *Les Villas d'Aurèle* (Haut-Rhin). – In: P. Lefranc, A. Denaire, C. Jeunesse (eds.), *Données récentes sur les pratiques funéraires néolithiques de la Plaine du Rhin supérieur*. BAR International Series 2633. Oxford, 2014, 173 - 210.

ЯМНА КУЛТУРА – КУЛТУРА НА ШНУРОВАТА КЕРАМИКА –
КУЛТУРА БЕЛ БЕКЕР,
ИЛИ КАК ДА РАЗБЕРЕМ СЪБИТИЯТА ПРЕДИ 5000 ГОДИНИ,
КОИТО СА ОФОРМИЛИ СЪВРЕМЕННА ЕВРОПА

Резюме

Фолкер Хайд

Статията представя кратък преглед на революционните събития през III-то хилядолетие пр. Хр., които са променили посоката на праисторическото развитие и са довели Европейския континент, и неговите обитатели, по-близо до съвременните държави. Започналите промени с миграцията на запад от носителите на Ямната култура, през степния коридор на Източна Европа, истинската трансформация настъпила с по-късните култури на шнуровата керамика и Бел Бекер. Носителите на тези култури разпространили своите социални ценности и светоглед и в най-западните райони. Настъпилата революция в съвременната археология, която е свързана с природните науки – изследване на древна ДНК, изотопни и антропологически изследвания, променя нашите традиционни разбирания за отминалите хилядолетия.



Figure 1 - The Yamnaya distribution in southeast Europe with approximate numbers of excavated kurgans and graves (background map after: Merpert, N.Ya. 1974. *Drevneishie skotovody Volzhsko-Ural'skogo mezhdurech'ya*. Moskva).

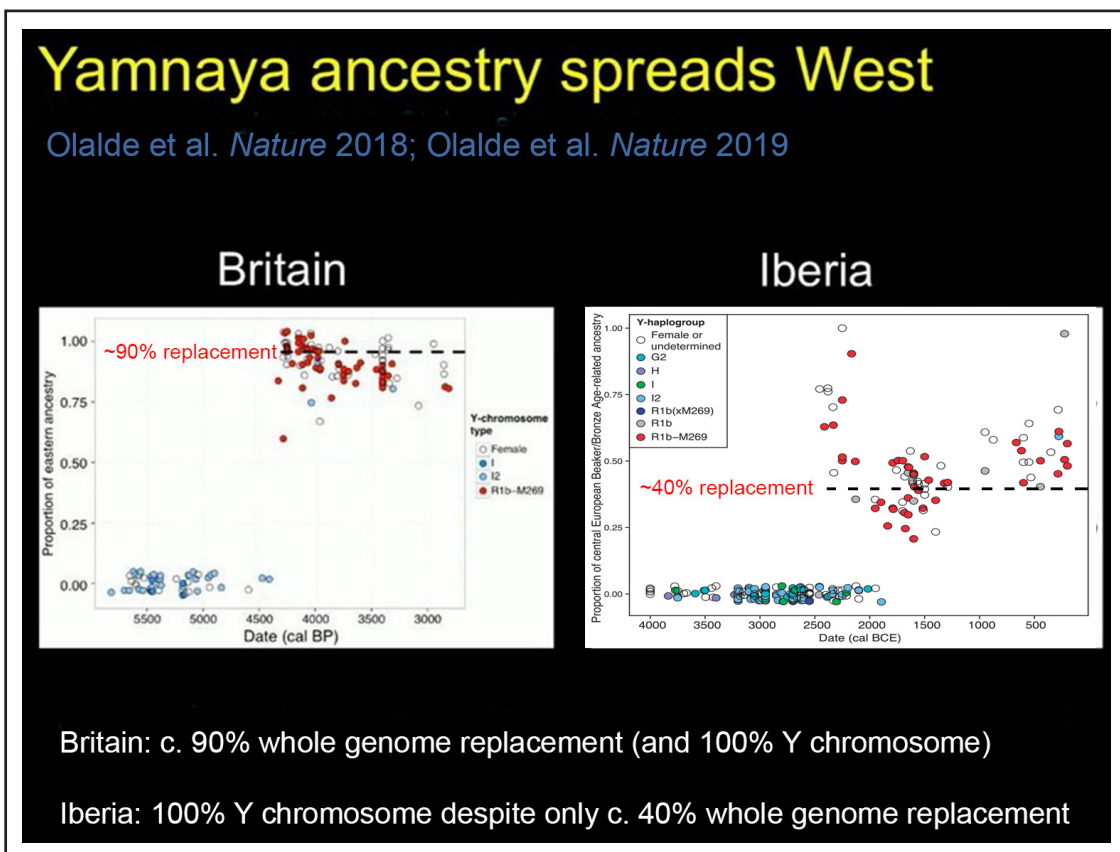

Figure 2 - Yamnaya ancestry spreads westwards (based on data published in Olalde et al. 2018 and Olalde et al. 2019, amended).

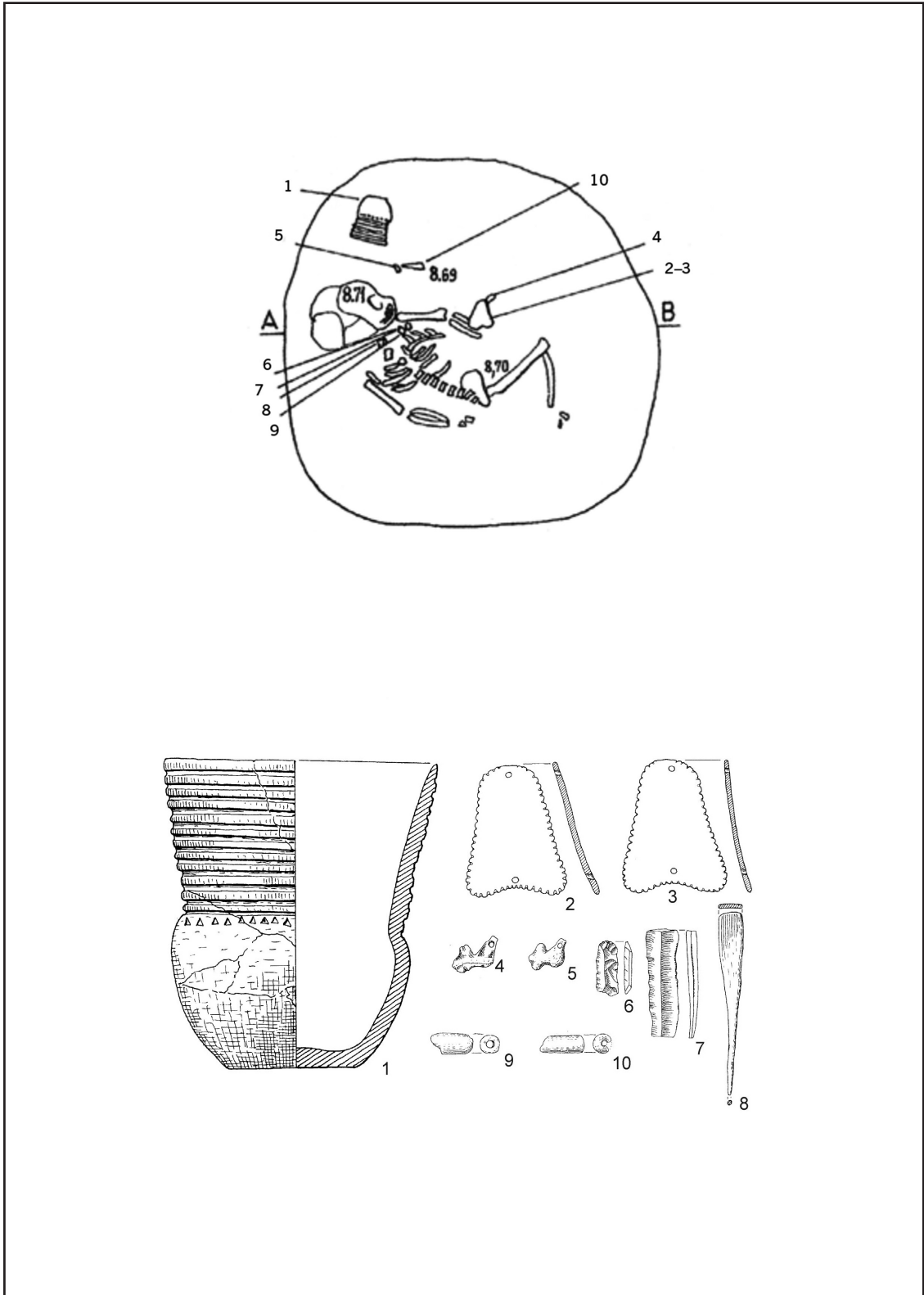

Figure 3 - The early Corded Ware grave of Krusza Zamkowa, Central Poland (after: Goslar, Koško 2011)



Figure 4 - The Bell Beaker East-Group graves of Sierentz (Haut-Rhin, Grand-Est, France), nos. 68 and 69 represent two brothers buried next to each other (after: Vergnaud 2014).

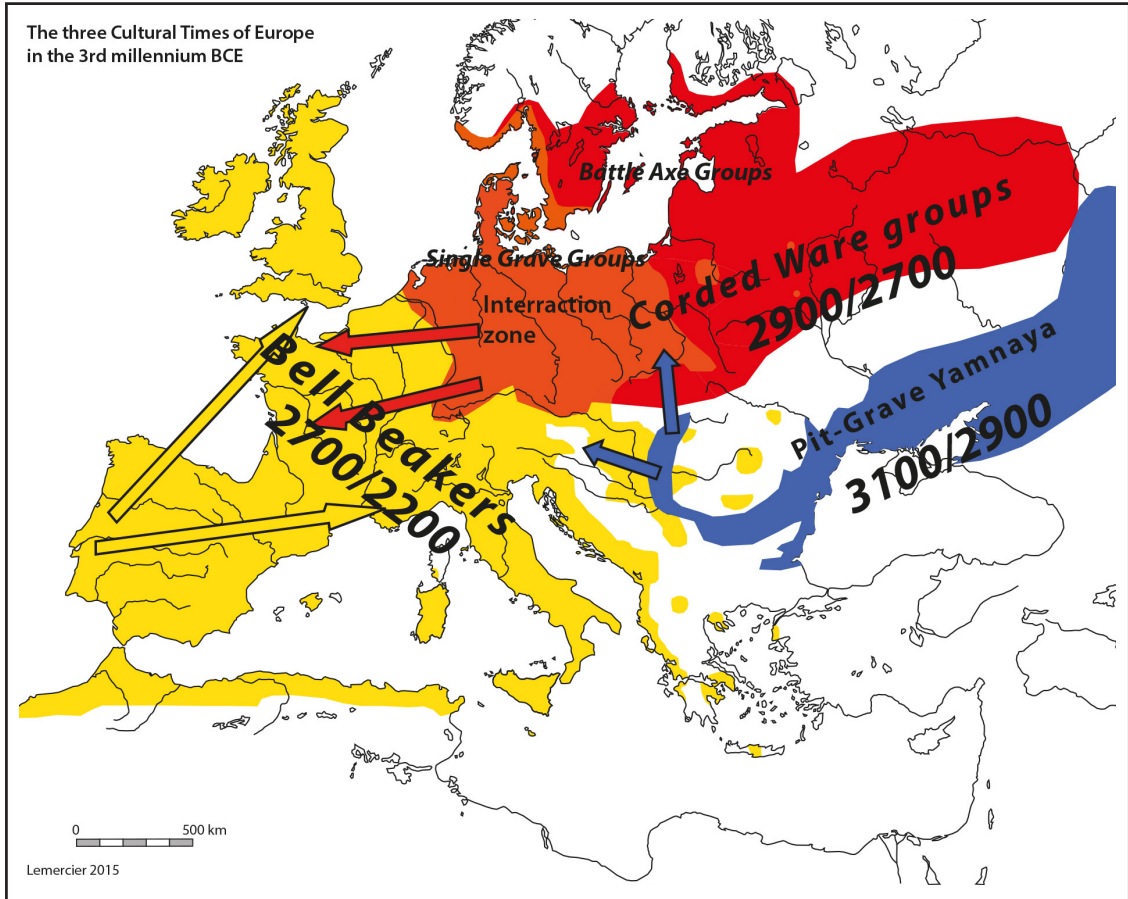

Figure 5 - Yamnaya – Corded Ware – Bell Beaker distribution in Europe (reproduced from Lemerrier 2018, Fig. 7).